

MWH

MOTOR WINDING HEATER CONTROLLER

200 - 600V / 10 - 80A / 3 - 900HP

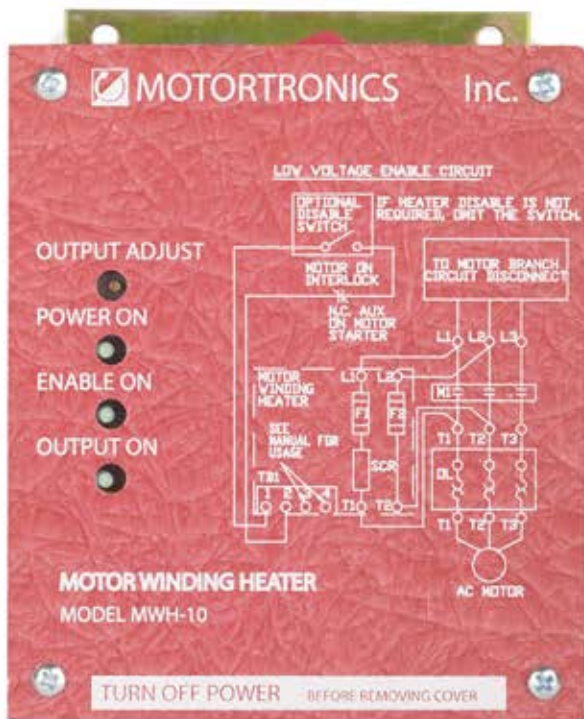

The MWH Series keeps motors warm & moisture-free during extended shut down periods.

Perfect for Marine Applications.

No motor strip heaters to fail.



MWH: Easy to Install with Built-in Protection

Motor Winding Heaters

Even the best motor winding insulation materials become water permeable with repeated exposure to temperature extremes and moisture. If the ambient temperature is below the "dew point" when a motor is turned off, condensation will form inside the motor as it cools down.

When the motor is re-energized, the moisture heats up and permeates the windings, eventually shorting and damaging the motor. Airborne corrosive elements like salt and chemicals can also combine with condensation and erode the rotor and bearings, leading to premature motor failure.

The MWH Series provides a cost effective solution to these problems by preventing condensation build-up in motors. By applying a low level current to the motor windings during extended shut down periods, the MWH Series keeps AC motors warm and moisture-free.

Fully Automatic Operation

Designed for fully automatic operation, the MWH Series turns on when the motor starter has turned off. A built-in one minute timer ensures that the motor magnetic field has collapsed before it injects DC power into the windings. When the motor is restarted, the MWH Series instantly turns off. No operator interface is required... the MWH Series is in control.

Built-in Overload Sensing

The MWH Series had an optional shutdown input that can be connected to the N.O. auxiliary contact on the motor starter's thermal overload relay. This will disable the motor winding heater control, preventing any additional heating in the motor and allowing for a faster motor cool down period. The MWH Series then goes back on-line after the overload relay is reset.

MWH Series



Easy to Install

Whether retrofitting an existing starter or installing a new one, the MWH Series is easy to apply. Just wire it in parallel to the magnetic starter's line and load connection, connect the necessary auxiliary contacts and installation is complete.

Simple Adjustment

Output voltage is factory set to maintain +5° to 10°C differential above ambient temperature. This adjustment can be used to trim the control as required for each application.

Self Protected

In addition to built-in fuse protection, the MWH Series features an RC snubber circuit across the SCR which protects it from any rapid rate of change in the system voltage. A metal oxide varistor (MOV) protects the unit against voltage spikes for reliable, maintenance-free operation.

Optional

Output contactor for service.

Notice

The MWH is designed for use with full voltage non reversing starters, use with other types of starters or VFD's will require isolation contactors and additional logic.

Ideal Alternative to Strip Heaters

Eliminate the cost and hassle of installing strip heaters into your motors. Simply wire up the MWH Series to generate heat throughout the motor stator windings. The heat is dissipated evenly without the "hot spots" caused by strip heaters. Conduction of heat to the rotor, bearings and shaft is also more effective which means maximized protection for the whole motor.

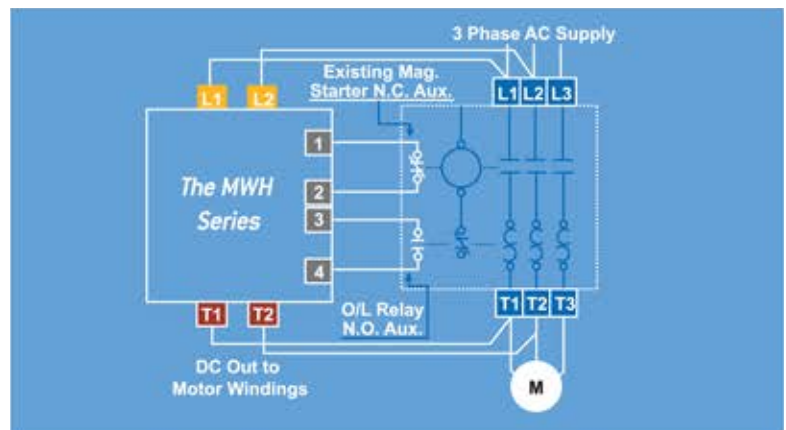

USA HEADQUARTERS

Motortronics / Phasetronics

1600 Sunshine Drive
Clearwater, Florida 33765
USA

Tel: + 727-573-1819 / 888-767-7792

Fax: + 727-573-1803 / 800-548-4104

E-mail: sales@motortronics.com

www.motortronics.com

UNITED KINGDOM

Motortronics UK

Bristow House,
Gillard Way, Ivybridge,
Devon, PL21 9GG,
United Kingdom

Tel: +44 (0)1752-894554

www.motortronics-uk.co.uk

SOUTH KOREA

Motortronics Int'l Korea Co Ltd

#1607, 128 Gasan digital 1-ro,
Gasan digital 1-ro,
Geumcheon-gu,
Seoul 08507, Republic of Korea

Tel: 82-2-867-5808

Fax: 82-2-867-6004

www.motortronics-korea.com

CHINA

M & P Machinery & Electronics Control

Part of the Motortronics Group

32 Jiaxin Road,
Jimo,
Qingdao, China 266229

Tel: 86-532-81725028

Fax: 86-532-81725038

www.mp-cn.com

UNITED ARAB EMIRATES

Motortronics MEA, LLC

Sharjah Media City,
Sharjah,
United Arab Emirates

www.motortronics.com

PN: MWH041526